



Urban **ECO**

PREFINISHED



SELFLOK

PRIMELOK

HIGH IMPACT PANEL

COMPLETE PREFINISHED INSTALLATION MANUAL

	CONTENTS	
General requirements		4-5
Selflok Installation		6-7
Primelok Installation		8-9
High Impact Installation		10-11

UrbanECO™ is our innovative prefinished range of natural timber cladding and architectural panels.

Why use prefinished?

Design - Available in smooth profiles with a wide range of COLORBOND® inspired colours.

Durable - The high quality and reliable coating system carries a 15 year guarantee provides a low maintenance solution.

Efficient - Lightweight, safe and simple to assemble with standard DIY tools.

Savings - With time saved on painting, scaffolding can be removed sooner

Flexibility - cutting time and cost off the project. No more down time when waiting to paint due to bad weather conditions.

What is Weathertex?

100% Australian made and owned, Weathertex® is manufactured from native Australian hardwood timber. Weathertex sources timber from sustainably managed forests and controlled sources audited under the Australian Forestry Standard (AFS) and Certified by PEFC: the world's largest forest certification scheme.

Weathertex proudly delivers natural, long-lasting timber products to customers in Australia and around the world. With a better than zero carbon footprint, Weathertex strives to provide quality products which enable creative and sustainable design for the future.

*Scan here to visit
UrbanECO on our
website ...*



NCC Compliance

All design, materials and construction must comply with the relevant requirements of the NCC and other applicable codes and standards.

Weatherex is ISO 9001 certified for quality and complies with the product standard AS 1859.4 (HB.E) Exterior Grade Hardboard.

Cutting & Safety

Standard health and safety precautions should be taken when working with timber products. Machine tools should be fitted with dust extractors and work areas kept clean. If dust levels exceed Work safe Australia Standards the wearing of a dust mask (AS 1715 and AS 1716) and safety glasses (AS 1337) is recommended.

Cut planks using a slide compound mitre saw with a high quality 80 teeth blade. Consistent cutting pressure and masking guards and jigs will prevent scratching and chipping of the surface.

Ground Clearance

Lower framing members must be isolated from ground moisture by suitable damp proofing. Similarly, Weatherex must not be placed in direct contact with masonry, brickwork or concrete. Where necessary use strips of Alcor flashing to isolate materials and use overhanging sarking at the base of the wall to isolate the Weatherex from slab work.

Allow at least 100mm clearance between the bottom edge of the Weatherex and sealed ground and at least 225mm clearance from unprotected ground.

The grade of adjacent ground must be sloping away from the building to avoid the possibility of water accumulation.

Framing

Weatherex is able to be installed onto timber or steel furring channels/tophats/battens. The requirements in this guide detail the connection of Weatherex cladding to the furring channels only. Detailing the structural connection and support requirements of the furring channels to the sub-frame must be completed by the project's structural engineer or a competent person.

Seasoned timber battens must be a minimum of 30mm in depth and H3 treated. Steel channels must have a minimum BMT of 0.55mm up to 1.2mm. Framing must be square, straight and true and free from dirt and contaminants.

Moisture Management & Flashing

Consideration must be taken to prevent moisture and condensation related risks accounting for interior and exterior environments of the building. Construction design must effectively manage moisture, particularly in buildings that have high risk of wind driven rain.

External wall junctions, penetrations and openings must be appropriately flashed in accordance with the NCC to prevent ingress into the wall cavity. Failure to appropriately flash these areas will void the manufacturers warranty.

On walls projecting from the roof line in upper storey construction, keep the bottom edge of the Weatherex material 70mm clear of roof claddings. Waterproof with an approved flashing.

Weatherex board is not suitable for wet areas where specifications require "water proof" materials. Refer to AS 3740 for guidance on wet area construction details.

Vapour Permeable Sarking

Vapour permeable sarking/membrane must be used under all light weight cladding products. The vapour permeable sarking allows for the controlled escape of water vapour from within the building whilst restricting the ingress of liquid moisture.

Sarking Requirements for Climate Zones 2 - 8	
Material Standard	AS/NZS 4200.1
Installation Standard	AS/NZS 4200.2
Mandatory Properties	
Vapour Resistance	LOW
Water Barrier	HIGH

*sarking products are unsuitable if "unclassified" as a water barrier and will void the product warranty

Soft compressible insulation installed directly between the front of the wall studs and Weatherex cladding can cause installation issues and is not suitable.

The permeability and vapour resistance of materials should be considered in the context of their application. The designers/architects/engineer should consider strategies to mitigate condensation risks in the design with relevance to local climate conditions. Suitable membrane products for moisture control in hot wet and humid conditions (Climate Zone 1) should be discussed with the membrane manufacturer.

Sealing Cut Edges

Sawn edges must be lightly sanded to remove loose fibers and sealed with high quality exterior acrylic primer before using joining accessories.

For exposed edges, also apply 2 coats of touch-up paint and wipe excess from the face surface. Allow appropriate drying time between coats.

Touch up Kit

The touch-up kit supplied should be used at the end of construction to fix any small marks in the paint.

Sealant & Glues

Application and use of sealant must comply with the manufacturers instructions. Sealant products must be checked for compatibility with the Weatherex system. Only high quality, flexible, paintable polyurethane sealants may be used. Where systems use construction adhesives, follow the installation instructions detailed for specified system.

Maintenance

Regularly wash the painted surface with soapy water to remove dirt and grime. Periodically inspect and repair any damage to coatings, substrate or sealants. Damage to the painted surface may be lightly sanded and touched up with the matching touch up paint kit when required.

Manufacturers Warranty

Underpinned by our 25 year guarantee not to rot, split or crack; Weatherex proudly delivers natural, long-lasting timber products to customers in Australia and around the world.

UrbanEco's durable coating system carries a 15 years guarantee against blistering, flaking or peeling.

Both the manufacturers warranty and the coating system warranty can be downloaded from the website: www.weatherex.com.au

Fasteners & Fixing

Structural wind load testing has been conducted in accordance with AS/NZS 4040 for non-cyclonic and cyclonic conditions. Wind classifications are determined as defined in AS4055 using a local pressure factor for planks within 1200mm of the building corner.

Tabulated results are for internally lined walls and are calculated using a local load factor = 2.

Minimum requirements for fasteners and the installation methods of this document must be followed for performance and wind zone classifications to be applicable.

NOTES:

1. Fasteners must be driven flush to the board surface as overdriving will dramatically reduce the holding capacity.
2. Minimum fastener length must be increased where any packing or thermal break material is used to ensure sufficient penetration into the structural sub frame.
3. Recommended fasteners may not be applicable for steel greater than 1.2mm BMT.
4. All fasteners must be galvanised or suitably coated to resist corrosion for external application. When installed in high corrosion zones such as coastal locations, fasteners must be made of materials appropriate to the durability required of the project. Contact fastener manufacturers for more information.

Storage & Handling

UrbanECO PREFINISHED panels are supplied ready for installation with no requirements for additional on-site painting. Care and diligence during handling and installation is important to avoid any damage to the painted surface. Original pallet packaging is not intended to be waterproof. When storing outside, cover with waterproof materials to prevent water staining.

Delivery to Site:

- During delivery ensure the pack is secured firmly to avoid transit damage
- Use corner protectors to avoid strap damage

Unloading on Site:

- Check the pack for transport damage when receiving
- Keep the pack level during handling
- Ensure forklifts and Hiabs do not damage pack sides during unloading on site
- Use corner protectors to avoid damage from slings

Storage on the Building Site:

- Store flat, under cover and clear of the ground
- Do not store in direct sunlight to ensure product is installed at an even equilibrium moisture content
- Original pallet packaging is not intended to be waterproof. When storing outside, cover with waterproof materials to prevent water staining

SELFLOK

SOFTWOOD TIMBER FRAMES - Fastener selection

Max Design Pressure	Non- Cyclonic Zone	Fastener Details	Max Stud Spacing
- 2.69 KPa	N1, N2, N3	Weatherex Hand Nail	450
- 2.79 KPa	N1, N2, N3	8g x 32mm c/sunk timber screw	450

0.75mm BMT STEEL FRAME

Max Design Pressure	Non- Cyclonic Zone	Fastener Details	Max Stud Spacing
-	N1, N2	8g x 40mm c/sunk Self Drilling Screw	450

PRIMELOK

SOFTWOOD TIMBER FRAMES - Fastener selection

Non- Cyclonic Zone	Cyclonic Zone	Fastener Details	Max Stud Spacing
N1, N2, N3, N4	C2	Weatherex Nail	450
N1, N2, N3	C1	Weatherex Nail	600
N1, N2, N3, N4	C2	8g x 40mm c/sunk timber screw	450

0.75mm BMT STEEL FRAME

Non- Cyclonic Zone	Cyclonic Zone	Fastener Details	Max Stud Spacing
N1, N2	N/A	8g x 40mm c/sunk Self-drilling Screw	450
N1, N2	N/A	2.5x 32mm SHMG Coil Nail (D41060)	450

Handling When Installing:

- Each pre finished panel is protected with a peel of plastic film which remains on the product up until fixing. Remove once installed
- Always lift the pre finished panel from the pack – Never slide the material as the risk of superficial damage to the coated surface is possible
- When trimming to size with a drop saw leave the protective film on the surface

Storage & Handling - Accessories

Anodised aluminium products should be stored in a dry and flat position away from any potentially corrosive materials. Timber or soft bearers at a distance no more than one metre apart should be used to support the product. Continuous exposure to moisture will promote corrosion.

The products are subject to damage or could damage incompatible materials they are brought in contact with. The edges and cut corners of the product can be sharp and may cause personal injury if not handled safely. Wear eye protection, gloves and protect skin when possible and when cutting avoid air borne metal fragments.

Prefinished Selflok Installation Method

Selflok Weatherboard Range



SELFLOK ECOGROOVE
150^ SMOOTH



SELFLOK ECOGROOVE
300^ SMOOTH

Specifications

Length	3660 mm
Width	298 mm
Thickness	9.5 mm
Lap	20 mm

^ Refers to groove spacing

Accessories

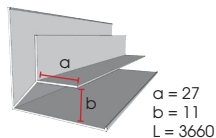

SMALL INTERNAL LF CORNER

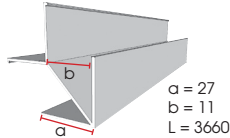

SMALL EXTERNAL LF CORNER

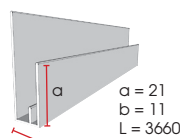

SMALL ALUMINUM
END STOP

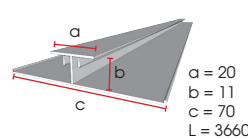

LONG VERTICAL
ALUMINUM JOINER

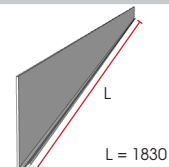

SELFLOK STARTER STRIP

Aluminium Accessories are available as standard silver anodised or colorbond colour matched powder coating

Frame Preparation

WeatherTex may be installed direct to timber framing, on a WeatherTex cavity system or to steel framing with thermal break batten. In each case follow the specific frame preparation instructions below before installation commences. **Framing must be at maximum 450mm stud spacing.**

Direct to Timber

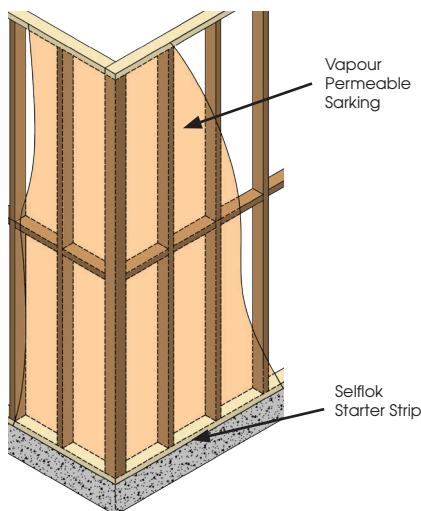

Cavity Installation

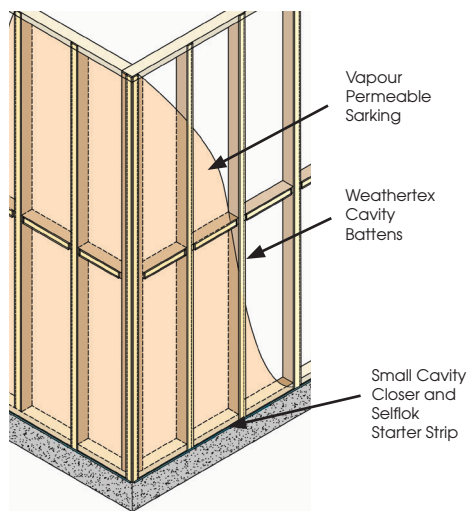

Steel Frame

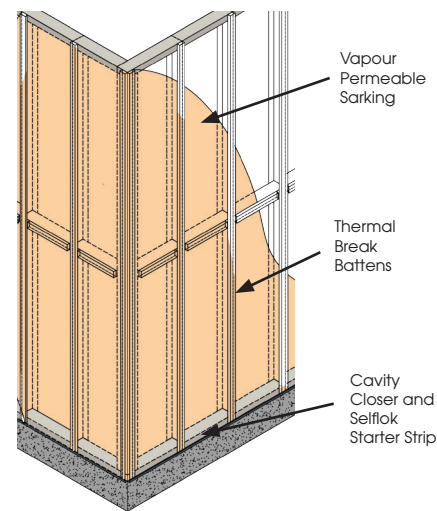

Step 1

Check and straighten framing as required.

Step 2

Install windows and appropriate flashings for all penetrations and openings.

Step 3

Install vapour permeable sarking and fit WeatherTex aluminum corner accessories.

Step 4

Install the Selflok Starter Strip, keeping level and butt joining successive lengths (may overhang the baseplate up to 20mm).

Step 1

Check and straighten framing as required.

Step 2

Install windows and appropriate flashings for all penetrations and openings.

Step 3

Install vapour permeable sarking and WeatherTex small cavity closer before attaching WeatherTex 45 x 9.5mm cavity battens vertically to each stud.

Step 4

Fit WeatherTex aluminum corner accessories.

Step 5

Install the Selflok Starter Strip, keeping level and butt joining successive lengths (may overhang the baseplate up to 20mm).

Step 1

Check and straighten framing as required.

Step 2

Install windows and appropriate flashings for all penetrations and openings.

Step 3

Install vapour permeable sarking and WeatherTex large cavity closer before attaching 20mm (R0.2) pine battens vertically to each stud as a NCC compliant thermal break.

Step 4

Fit WeatherTex aluminum corner accessories.

Step 5

Install the Selflok Starter Strip, keeping level and butt joining successive lengths (may overhang the baseplate up to 20mm).

Selflok Weatherboard Installation

Step 1

Place a dab of flexible sealant every 450mm in the V-notch of the Selflok rebate. The sealant operates as a dampener to prevent any acoustic rattle with cladding movement.

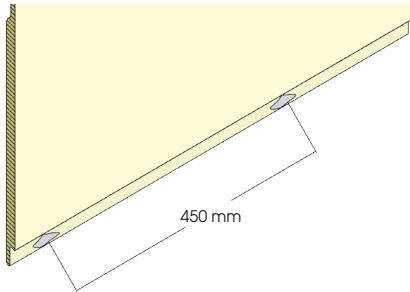

Step 2

Install the first row of boards by engaging the bottom rebated edge into the stater strip.

Direct Fix

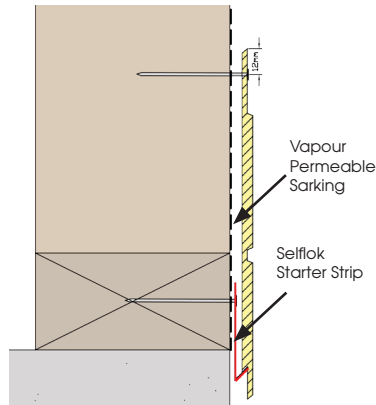

Batten System

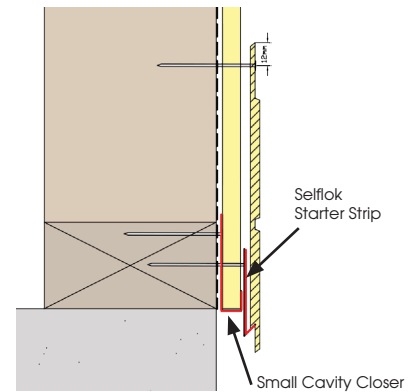

Step 3

Fix planks at every stud 12mm down from the top edge so that fixings will be fully concealed by the overlap of the next row. Fixings must be flush and not overdriven.

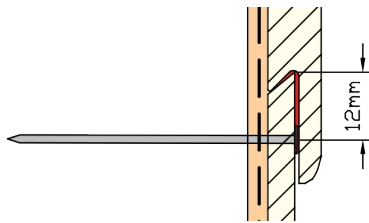

The application of sealant in Step 1 must be repeated for all planks as installation progresses. Care must be taken not to over apply sealant to prevent any excess from being squeezed from the plank lap.

Step 4

Joining Option A

Planks may be butt joined successively on-stud using an Alcore strip to back flash the joint. A 3mm control joint must be left to allow for expansion and contraction. Use touch up paint to seal cut ends.

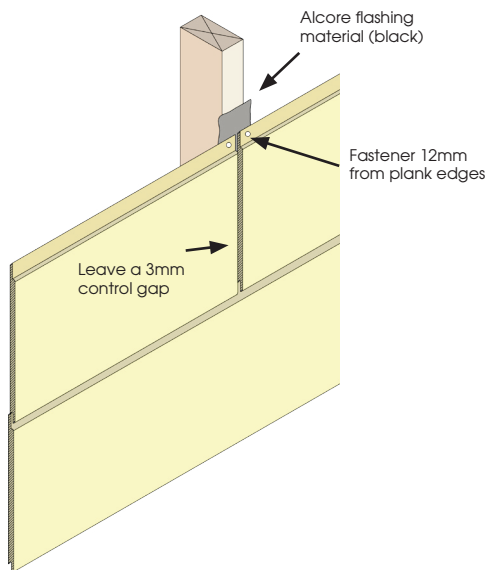

Joining Option B

Plank joints may be aligned and joined off stud with the Weathertex Long Vertical Aluminum Joiner. The aluminium joiner must be supported by noggins at 600mm centers.

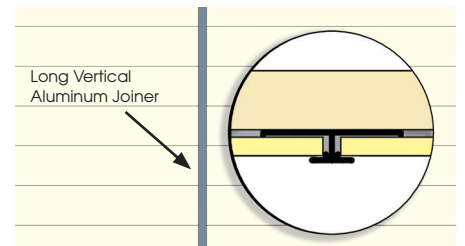

End Stops

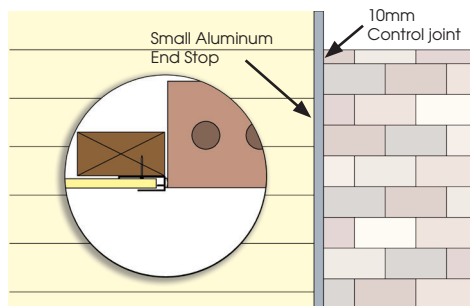

Weathertex Aluminum End Stops may be used vertically where planks butt into penetrations or masonry. Using a bond breaker, a 10mm control gap should be left and sealed between the aluminium and masonry surface.

External Corner

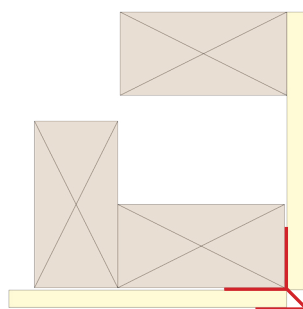

Internal Corner

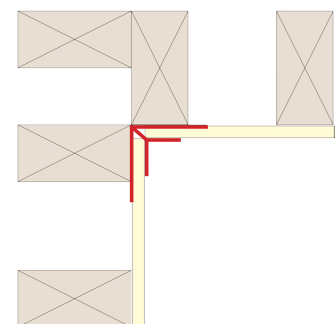

Weathertex Small Internal LF and Small External LF corner accessories provide a flashed control joint for 90 degree corners. Expansion gaps must be used when butt joining aluminium lengths greater than 6 meters high.

Primelok Weatherboard

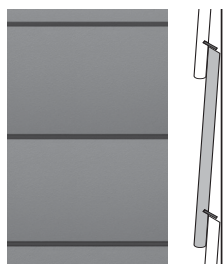

PRIMELOK 200 WEATHERBOARD

Specifications

Length	3660 mm
Width	197 mm
Thickness	9.5 mm
Lap	25 mm

Accessories

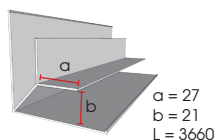

LARGE INTERNAL LF CORNER

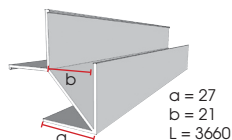

LARGE EXTERNAL LF CORNER

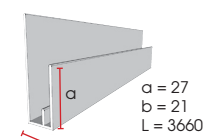

LARGE ALUMINUM END STOP

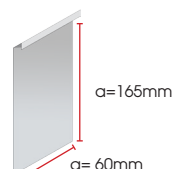

PRIMELOK OFF-STUD JOINT FLASHING

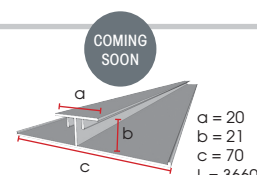

PRIMELOK LONG VERTICAL ALUMINUM JOINER

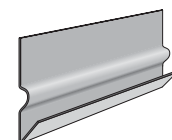

PRIMELOK STARTER STRIP

Aluminium Accessories are available as standard silver anodised or colorbond colour matched powder coating

Frame Preparation

WeatherTex may be installed direct to timber framing, on a WeatherTex cavity system or to steel framing with thermal break batten. In each case follow the specific frame preparation instructions below before installation commences. **Framing must be at maximum 450mm stud spacing.**

Direct to Timber

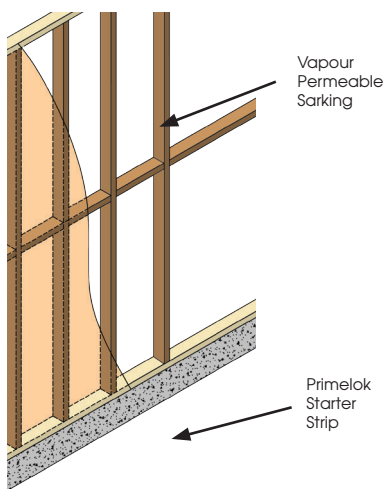

Step 1

Check and straighten framing as required.

Step 2

Install windows and appropriate flashings for all penetrations and openings.

Step 3

Install vapour permeable sarking and fit WeatherTex aluminum corner accessories.

Step 4

Install the Primelok Starter Strip, keeping level and butt joining successive lengths (may overhang the baseplate up to 20mm).

Cavity Installation

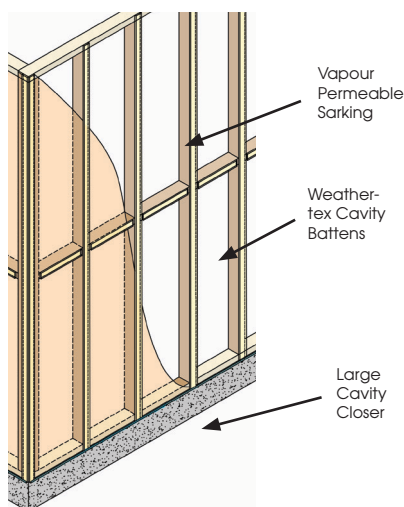

Step 1

Check and straighten framing as required.

Step 2

Install windows and appropriate flashings for all penetrations and openings.

Step 3

Install vapour permeable sarking and WeatherTex Large cavity closer **before** attaching WeatherTex 45 x 9.5mm cavity battens vertically to each stud.

Step 4

Fit WeatherTex aluminum corner accessories.

Step 5

The large cavity closer acts as the starter strip in this case

Steel Frame

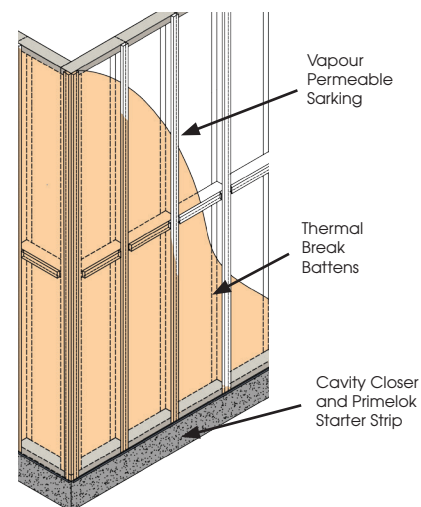

Step 1

Check and straighten framing as required.

Step 2

Install windows and appropriate flashings for all penetrations and openings.

Step 3

Install vapour permeable sarking and WeatherTex large cavity closer **before** attaching 20mm (R0.2) pine battens vertically to each stud as a NCC compliant thermal break.

Step 4

Fit WeatherTex aluminum corner accessories.

Step 5

Install the Primelok Starter Strip, keeping level and butt joining successive lengths (may overhang the cavity closer up to 20mm).

Primelok Weatherboard Installation

Step 1

Install the first Primelok plank by engaging the plastic spline into the Starter Strip. Check level and fasten off 15mm down from the top edge at each stud.

Direct to Frame

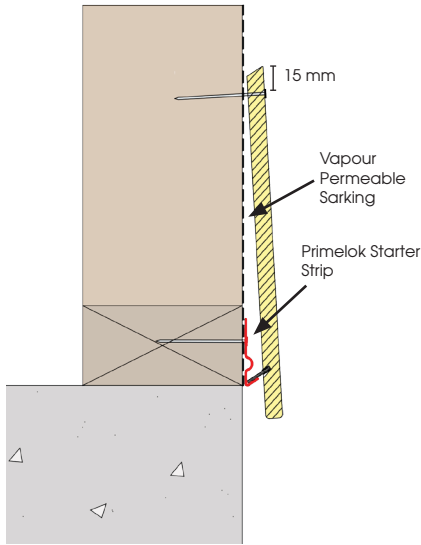

Weatherex Cavity System

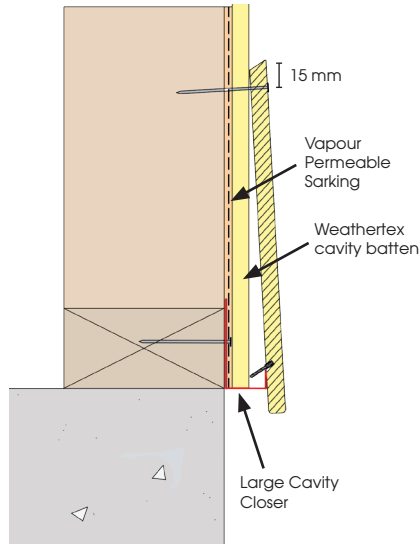

Steel Frame & Thermal Break

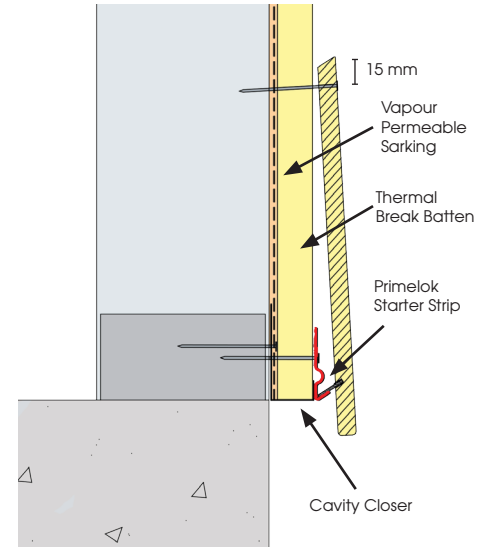

Step 2

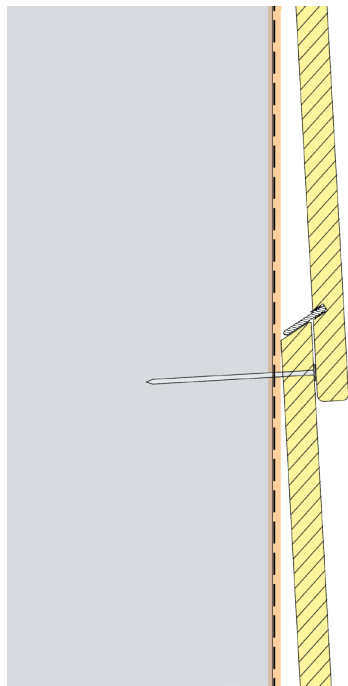

Fasten each weatherboard along the top edge at every stud. Keep fasteners 15mm down from the top edge so they will be hidden by the overlapping board above.

Install successive rows by engaging the Primelok Spline with the angled edge of the board below and applying downward pressure while fixing off. Check rows for level as work progresses up the wall.

The flexibility of the PVC spline allows for 1-2mm adjustment of row level. Marking level around corners with a square can help prevent creep between adjacent walls due to uneven installation down pressure.

Step 3

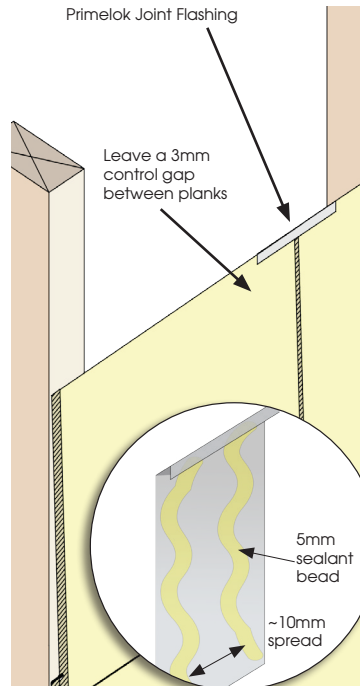

Fit Primelok Off-stud Joint Flashings as work proceeds. Apply two 5mm beads of polyurethane sealant down the length of the flashing, offset so there is no sealant in the joint between planks.

Hooking the flashing over the top of the Primelok plank and lapping the row below, center the flashing at the plank joint, leaving a 3mm control gap between plank ends.

The spline will need to be trimmed back for cut planks. This is easily done with aviation tin snips.

End Stops

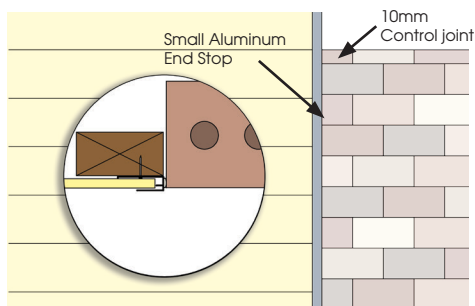

Weatherex Aluminum End Stops may be used vertically where planks butt into penetrations or masonry. Using a bond breaker, a 10mm control gap should be left and sealed between the aluminium and masonry surface.

External Corner

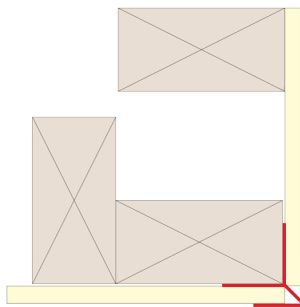

Weatherex Large Internal LF and Large External LF corner accessories provide a flashed control joint for 90 degree corners. Expansion gaps must be used when butt joining aluminium lengths greater than 6 meters high.

Internal Corner

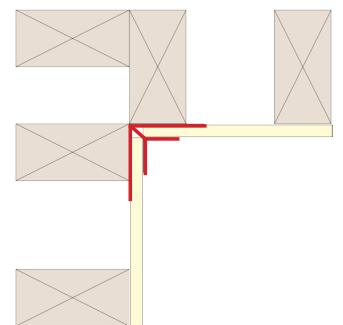

Prefinished High Impact Panel

Maximum sheet size 3660 x 1220 x 9.5mm

Accessories Provided by Weathertex

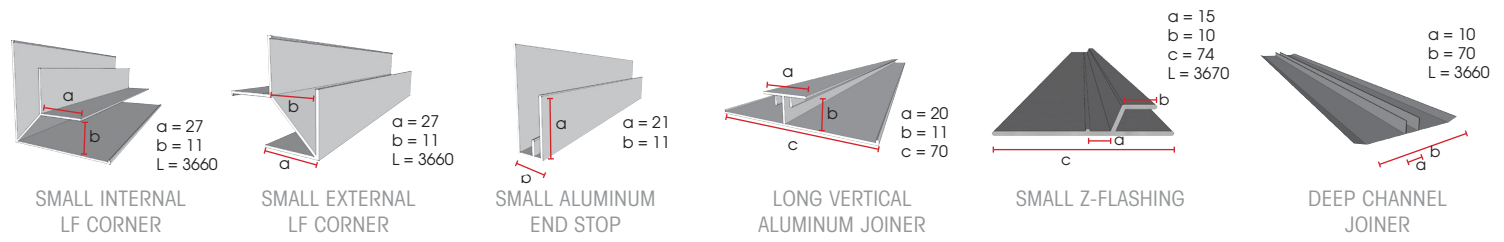

Aluminium Accessories are available as standard silver anodised or colorbond colour matched powder coating

Components Not Provided by Weathertex

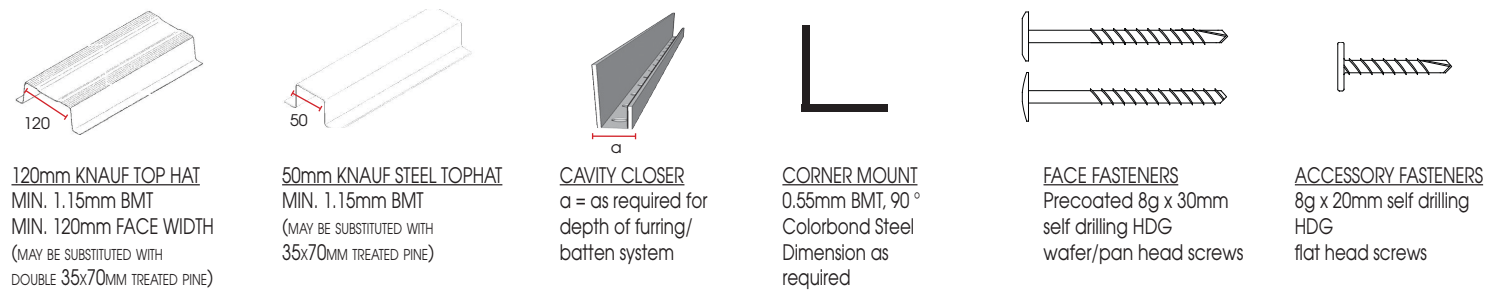

NB: minimum fastener dimension listed

Sub-frame Preparation & Top-hat Layout

Check and straighten substructure as required. Install windows and appropriate flashings for all penetrations and openings (refer to NCC requirements). Install vapour permeable membrane over the subframe in accordance with the manufacturers instructions.

Structurally secure and support steel tophats or treated pine battens to the subframe. Configurations will vary depending on the width of the panel being installed.

Vertical joints are supported by a wide faced tophat while the panel body is supported by an intermediate tophat. The Deep Channel Joiner or Long Vertical Aluminium Joiner is centered on the wide faced tophat allowing both vertical edges of adjoining panels to be fastened.

The intermediate stud is placed halfway between the double width tophat arrangements for up to a maximum sheet width of 1220mm.

When laying sheet configurations with widths greater than 1220mm intermediate tophats must be placed a maximum 600mm centers, dividing the locations of vertical joints at equally spaced intervals.

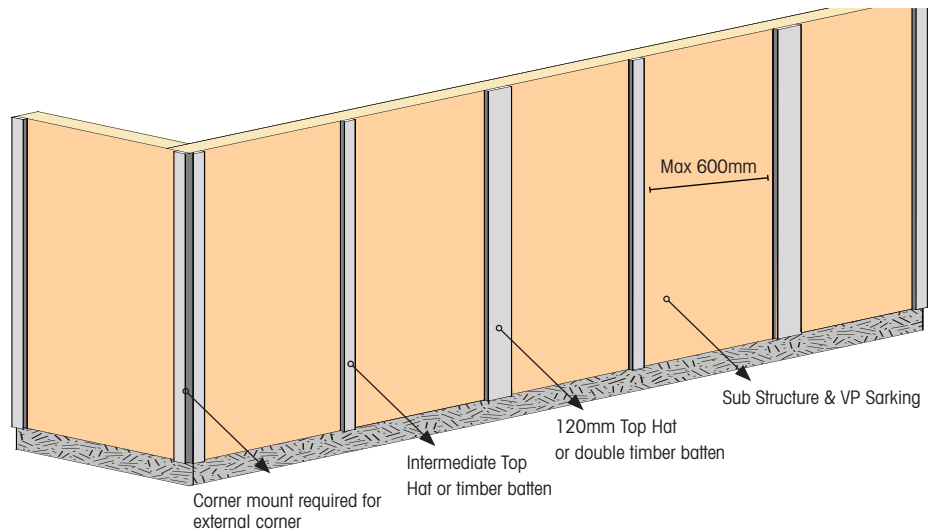

CAVITY CLOSER - VERMIN PROOFING

Install appropriate vermin proofing to close of the cavity created by the batten system. The cavity closer must be sufficiently perforated to enable any water ingress to drain.

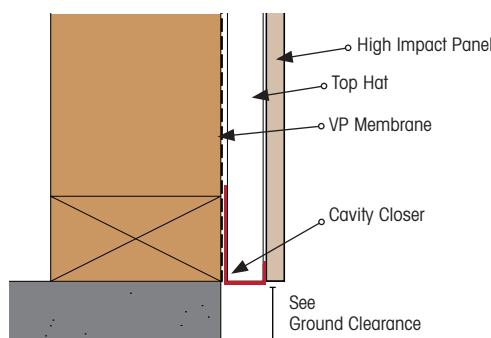

CORNER DETAIL

Install internal and external corner accessories and endstops as required before panel installation begins. External corners require a 90° colorbond mount to bridge corner tophats.

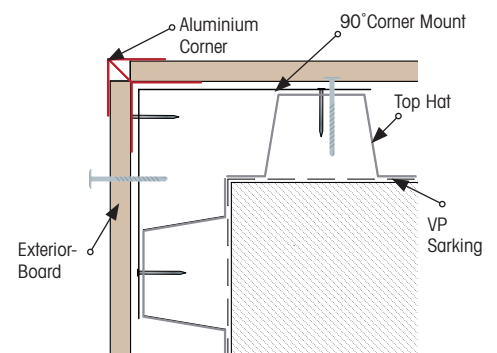

High Impact Panel Installation

Step 1

Starting at the corner, insert the first panel into the corner accessory keeping the vertical edge level. When using the deep channel joiners, it is important to ensure the vertical edge is level as any tolerance issues can be taken up with the horizontal z-flashing.

Fasten off 30mm up from the bottom edge of the sheet and approximately 30mm in from the panel edge at the location of the corner tophat. Fix a second fastener 600mm up from the first on the same edge to temporarily hold the panel in place.

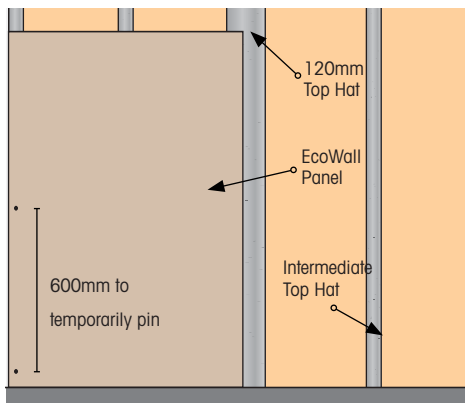

Step 2 - Vertical Joints

Slide the vertical jointer into place on the free vertical edge. Tophat layout should allow the accessory to be centered on the wide tophat.

Fasten the jointer to the frame through the exposed backing wing in two locations to hold it in place.

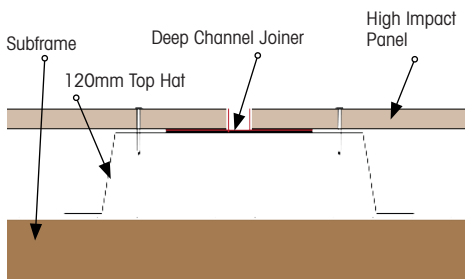

Detail: Deep Channel Joiner

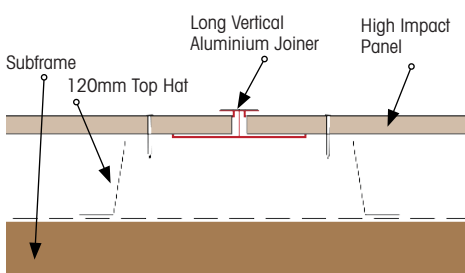

Detail: Long Vertical Aluminium Joiner

Step 3

Fasten off the panel edge at the same heights and spacing from the joining accessory as the opposite side. Repeat this process for the row of panels.

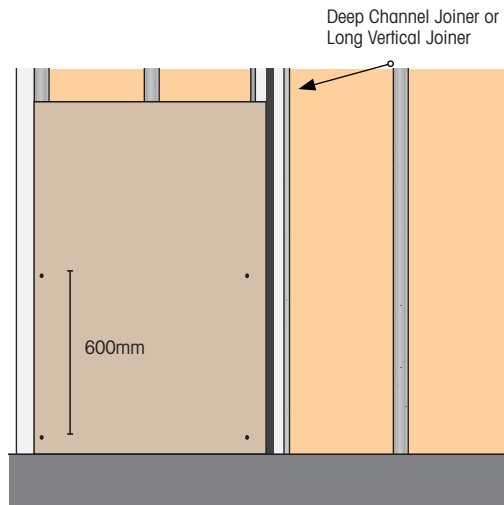

Step 4 - Horizontal Joints

Full sheets and cut panels can be stacked vertically to create various configurations. Horizontal joints can also be staggered at differing heights across a wall for a brick-lay effect.

To join panels horizontally the small aluminium z-flashing is cut to fit between the selected vertical accessories. The z-flashing is inserted above the installed bottom sheet, butting into the vertical accessory at either end.

Use a piece of softwood to tap and maneuver the z-flashing level and fasten off at each tophat 15mm down from the top edge of the z-flashing with a 20mm Flat Head Screw.

Note: Alternatively, vertical joining accessories may be cut to panel height and the small z-flashing ran continuously horizontal.

The panel above is then slid into place with the bottom edge resting on the spacer nib of the z-flashing accessory. Secure panel as previously described.

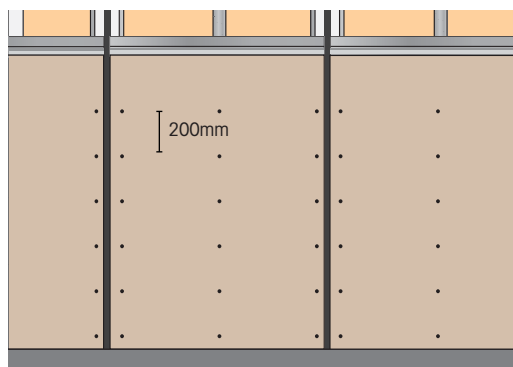

Note: Do not fasten off panels fully until horizontal joints are in place as it will make it difficult to install the z-flashing accessory.

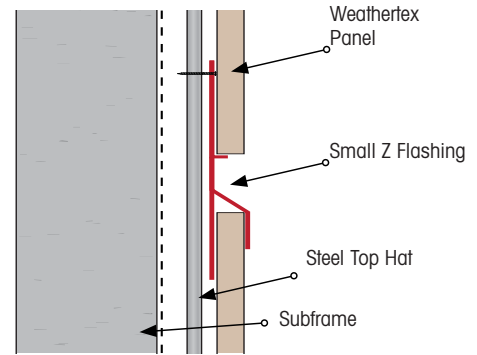

Step 5 - Fixing Off

Once in place panels must be fastened off at 200mm centers down each panel edge and intermediate tophats (pre-drill panels first). Keep fasteners 30mm in from panel edges.

As fasteners are exposed and are a feature of the installation, ensure fasteners are geometrically aligned across all sheets. Care taken in this step will provide the best visual results.

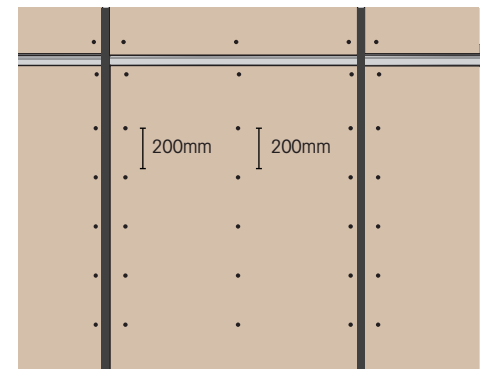

Additional Installation Tips

- It is important that the vertical jointer is centered across the double tophat. Installing tophats as the installation of panels proceeds will prevent issues with creep at these joints.
- Sheets may be rotated and installed horizontally or cut down to create different wall patterns.
- Panel and tophat installation must allow for expansion joints in steel subframes.
- 35x70mm timber battens may be substituted instead of steel tophats. In this case a double batten must be used for vertical joints.

COMPLETE PREFINISHED COLOUR RANGE

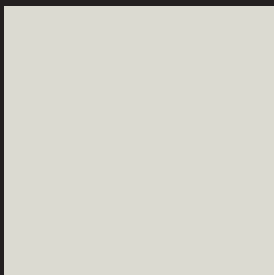

SURFMIST®

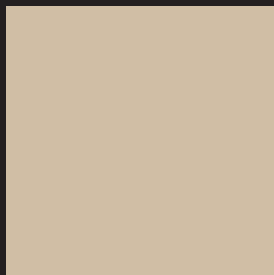

PAPERBARK®

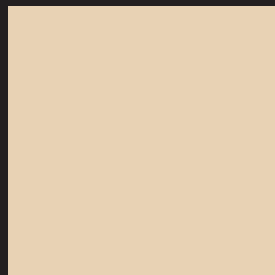

CLASSIC CREAM™

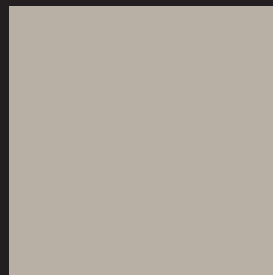

DUNE®



JASPER®



DEEP OCEAN®



IRONSTONE®



MANOR RED®



WOODLAND GREY®

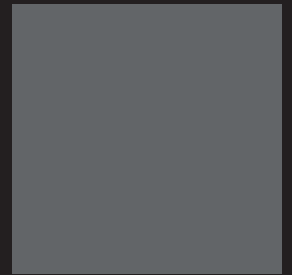

MONUMENT®



weathertex

timber made perfect, naturally

weathertex.com.au Ph: 1800 040 080 Fax: 1800 647 926



For additional construction details visit weathertex.com.au or call our customer service line on 1800 040 080 (Mon-Thurs 8am-5pm, Fri 8am-4pm Eastern Standard Time). UrbanECO is sold by Bowens. For more information including store locations, visit bowens.com.au

Disclaimer: The information in this manual related to WeatherTex's product as developed and manufactured at the time of printing. Importantly, WeatherTex follows a policy of continuous product testing and improvement. For this and other reasons WeatherTex reserves the right to make any changes or modifications to this manual and any other relevant document as and when it considers necessary and without notice. Accordingly users of WeatherTex products are encouraged to regularly contact WeatherTex to obtain the current manual. Last reviewed 1st May 2017.



* Refer to the WeatherTex Manufacturer's Warranty Conditions